



Key Features

- Best in class image quality
- Ultra High Resolution
- 6µm pixel pitch
- 16 bit output
- CLHS and GenICam compliant

Applications

- Industrial inspection
- Biomedical
- Scientific

RadEye XR Industrial X-Ray Detector

Overview

Teledyne DALSA, a worldwide leader in high performance X-ray imaging is introducing a new product, the RadEye XR, an ultra high resolution industrial dynamic detector. The RadEye XR detectors are designed to address the demanding needs of Industrial inspection, biomedical and scientific applications.

These detectors are available with different Gd2O2S (GadOx) scintillator options to address a range of resolution and sensitivity requirements. The RadEye XR cameras are compliant with GenICam™ and CameraLink HS™ (CLHS) specifications delivering 16 bits of data. The Camera interface allows for easy access to feature such as adjusting the frame rate, single or multiple frames acquisition and control of advanced timing modes. Each detector ships with user-friendly software tools for stand-alone operation or easy integration with your application software.

Specifications

Camera Specifications	RadEye XR	Units
Resolution	6	µm
Number of Pixels	10720 (H) x 8064 (V)	
Active area	64.3 x 48.4	mm
Framerate	16	fps
Digitization	16	bits

General

Weight of camera	< 1	kg
Operating temperature	0 to 50	°C
Storage temperature	-10 to +65	°C
Humidity (non-condensing)	10 to 80	% R.H.

RadEyeXR Product Family Pre-Datasheet

Specifications

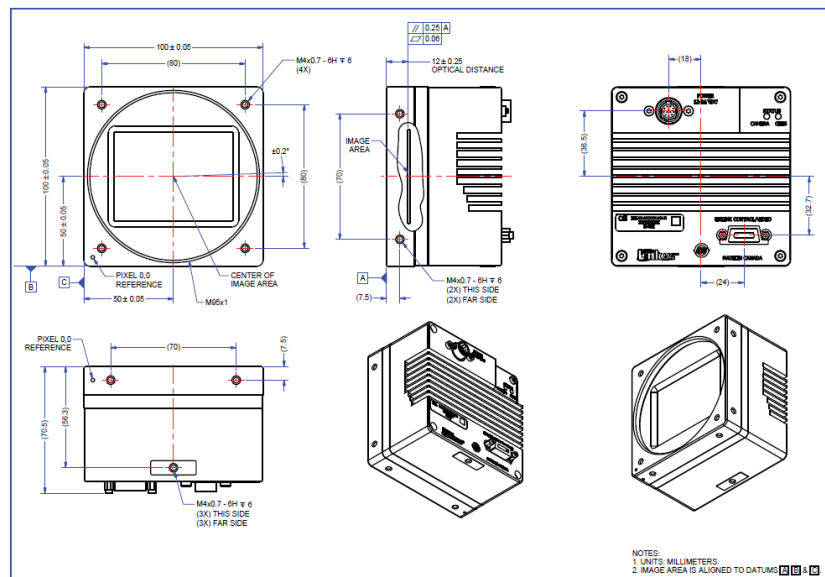
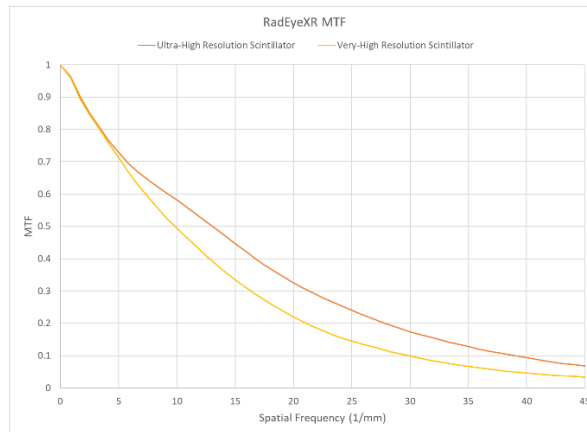

Contact Information

Teledyne Rad-icon Imaging,
A BU of Teledyne Digital Imaging US, Inc.
765 Sycamore Drive, Milpitas, CA 95035
(408) 736-6000
sales.rad-icon@teledynedalsa.com

Teledyne Digital Imaging US, inc is a wholly owned subsidiary of Teledyne Technologies Inc.
Teledyne DALSA has its corporate offices in Waterloo, Canada.
Teledyne DALSA reserves the right to make changes at any time without notice. © 2024 | v1.00